



**WE LISTEN. WE OBSERVE. WE OPTIMIZE.**

# **DYNA-FAST**

## **FOOT ACTIVATED SCREENING THERMOMETER**

**62110**  
Forehead  
Thermometer  
Included



**62111**  
Forehead  
Thermometer  
Not Included





# TABLE OF CONTENTS

<b>1. Title</b>	<b>1</b>
<b>2. Contents</b>	<b>2</b>
<b>3. Description</b>	<b>3</b>
<b>4. Intended Use</b>	<b>3</b>
<b>5. Foreseeable Misuse</b>	<b>3</b>
<b>6. Important Safety Instructions</b>	<b>4</b>
<b>7. Set Up</b>	
<b>7.1 Wall Mounting</b>	<b>4</b>
<b>7.2 Thermometer Installation</b>	<b>6</b>
<b>7.3 Battery Installation</b>	<b>7</b>
<b>7.4 Cable Adjustment</b>	<b>8</b>
<b>8. Operation</b>	<b>9</b>
<b>9. Maintenance</b>	<b>10</b>
<b>10. Dimensions</b>	<b>10</b>
<b>11. Parts Diagram</b>	
<b>11.1 Lower Housing</b>	<b>11</b>
<b>11.2 Upper Housing</b>	<b>12</b>
<b>11.3 Cable</b>	<b>13</b>
<b>12. Warranty</b>	<b>14</b>



## 3. DESCRIPTION

The Dynabrade Foot Activated Screening Thermometer (DYNA-FAST) is a hands-free system for independently checking body temperature. The system's foot activated switch prevents the transfer of germs from person to person by surface contact, and its self-service design allows correct social distancing to be maintained since a dedicated thermometer operator is not required.

The DYNA-FAST secures an infrared forehead thermometer and uses a foot pedal, cable, and linkage to actuate the thermometer's switch. The rearward facing temperature reading is displayed with an arrangement of two mirrors.

## 4. INTENDED USE

The DYNA-FAST is intended to be used as a body temperature screening system to let individuals privately see their own temperature. The DYNA-FAST is for indoor use only and must be securely wall mounted adjacent to an Instructions for Use poster. The DYNA-FAST is for use with a non-contact, front switch, forehead thermometer. The DYNA-FAST is for individuals with the ability to use their foot to press a switch at floor level while their forehead is aligned with the thermometer.

## 5. FORESEEABLE MISUSE

**Misuse could include but isn't limited to the following:**

- Set up and installation without reading this manual
- Using the DYNA-FAST without reading this manual
- Un-secure wall mounting
- Instructions for Use not posted
- Outdoor use
- Touching the DYNA-FAST with hands during use
- Misalignment of forehead to thermometer during use



## 6. IMPORTANT SAFETY INSTRUCTIONS

READ ALL PARTS OF THIS MANUAL CAREFULLY BEFORE USE AND KEEP FOR FUTURE REFERENCE

### Definitions:

**⚠ WARNING** Indicates a hazardous situation that, if not avoided, could result in death or serious injury.

**⚠ CAUTION** Indicates a hazardous situation that, if not avoided, could result in minor or moderate injury.

**⚠ WARNING** Cancer and Reproductive Harm – [www.P65Warnings.ca.gov](http://www.P65Warnings.ca.gov)

## 7. SET-UP

### 7.1 Wall Mounting (Figure 1)

- 1) Securely fasten the UPPER HOUSING to a wall using #10 fasteners (not included).  
Position UPPER HOUSING to accommodate the height of the shortest anticipated user.

**⚠ CAUTION** To avoid impact injury, secure UPPER HOUSING to wall

**⚠ CAUTION** To prevent error, do not mount in direct sunlight or in draft

- 2) Securely fasten the LOWER HOUSING to the wall using #10 fasteners (not included).  
Mount at floor level, centered below the UPPER HOUSING within +/- 1 inch.

- 3) Securely fasten the CABLE to the wall using supplied LOOP CLAMPS.

**⚠ CAUTION** To avoid entanglement or tripping injury, secure LOWER HOUSING and CABLE to wall.



# 7. SET-UP

## 7.1 Wall Mounting (Figure 1)

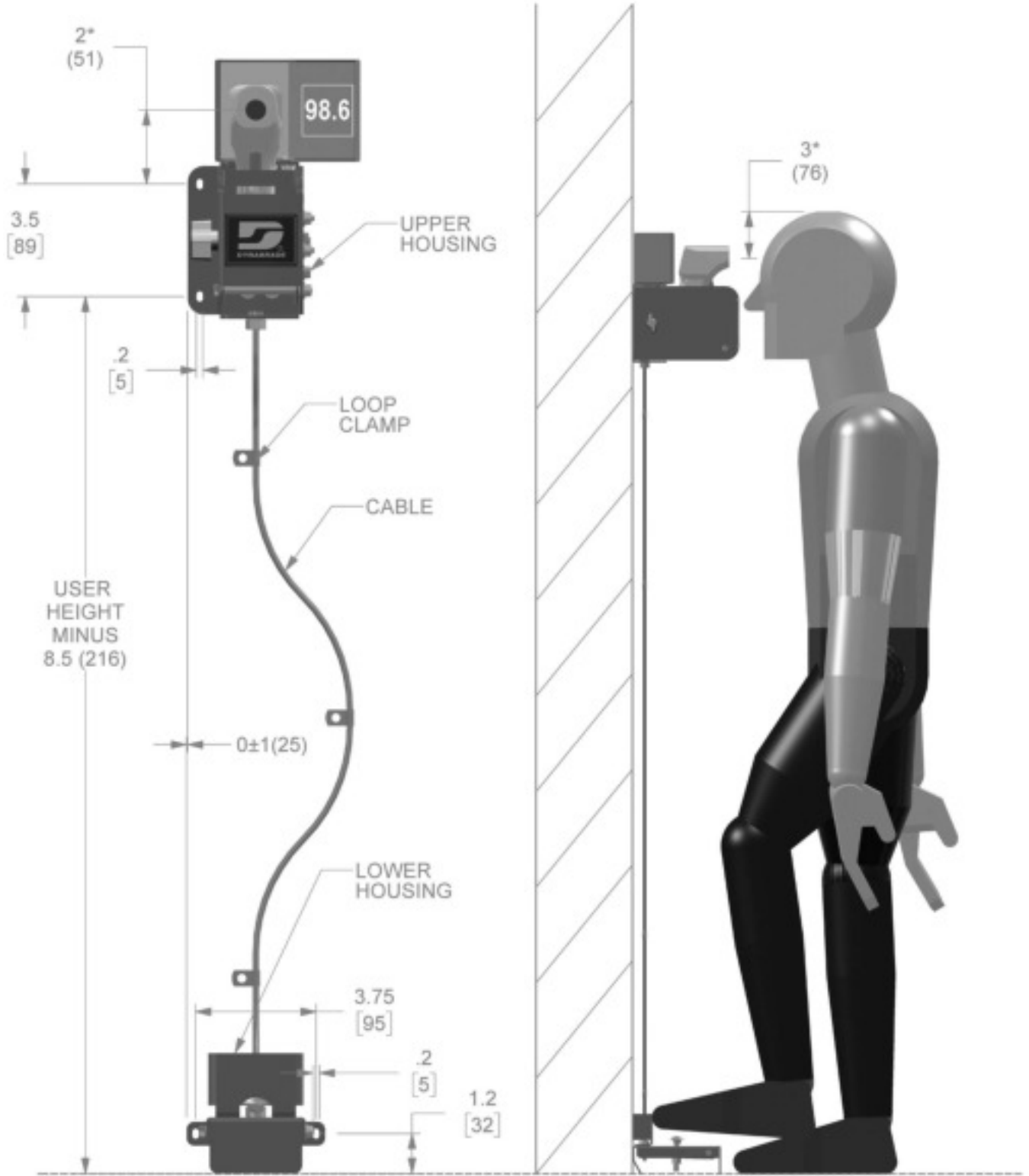

\* APPROXIMATE DIMENSIONS FOR REFERENCE ONLY



# 7. SET-UP

## 7.2 Forehead Thermometer Installation (Figure 2)

- 1) Loosen FRONT and REAR LOCKING NUTS (3/8" wrench) CLAMPING SCREWS (#2 Phillips screwdriver)
- 2) Position FRONT CLIPS to align forehead thermometer SWITCH with TRIGGER then tighten FRONT LOCKING NUTS
- 3) Tighten CLAMPING SCREWS to secure forehead thermometer
- 4) Tighten REAR LOCKING NUTS

Figure 2

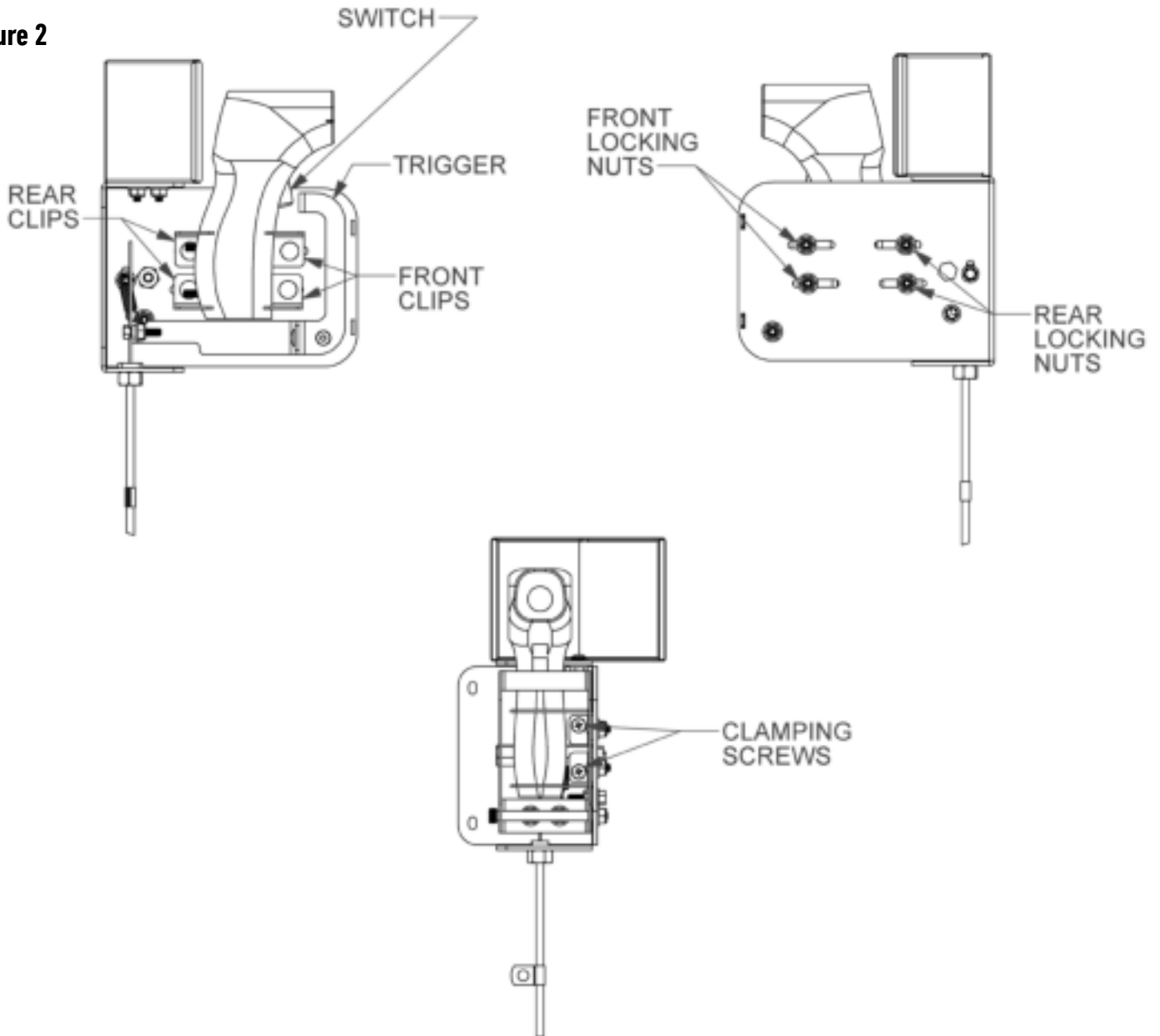



# 7. SET-UP

## 7.3 Forehead Thermometer Battery Installation (Figure 3)

- 1) Confirm size and polarity of batteries and install as indicated on the forehead thermometer housing
- 2) Follow local guidelines when disposing of used batteries

Figure 3

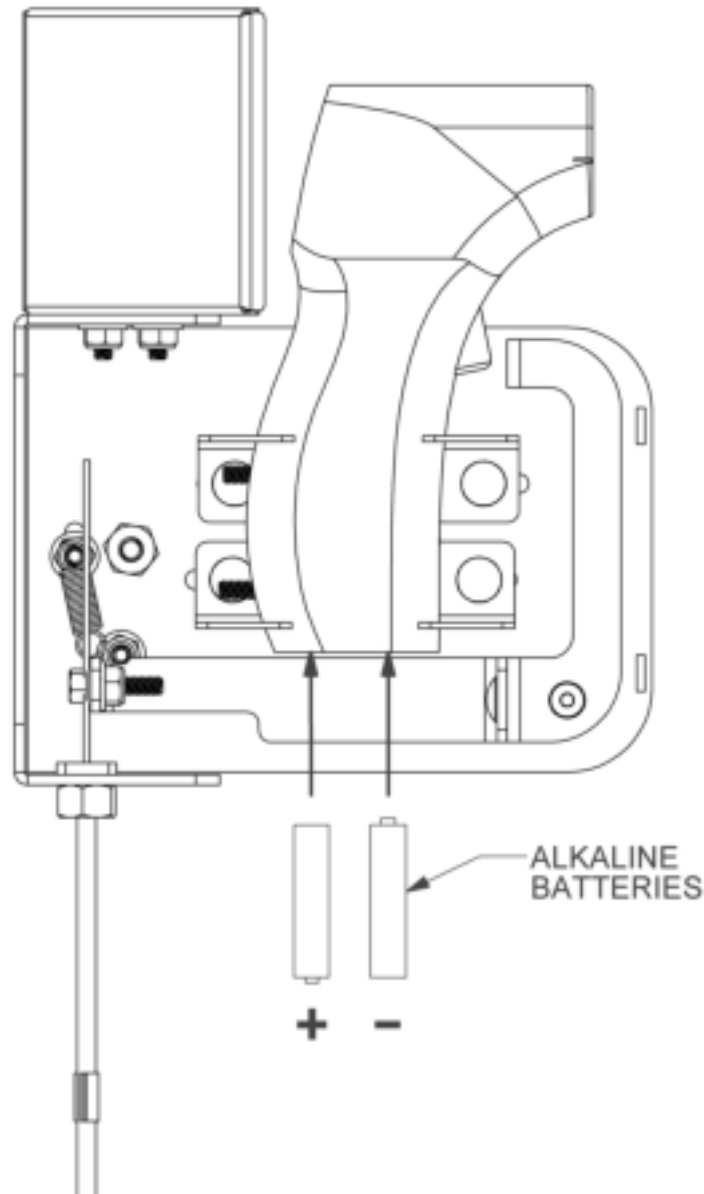



# 7. SET-UP

## 7.4 Cable Adjustment (Figure 4)

- 1) Loosen NUT to allow CABLE adjustment. SPRING will pull TRIGGER BAR up to the STOP
- 2) Pull CABLE up to remove slack, then tighten NUT to secure CABLE

Figure 4

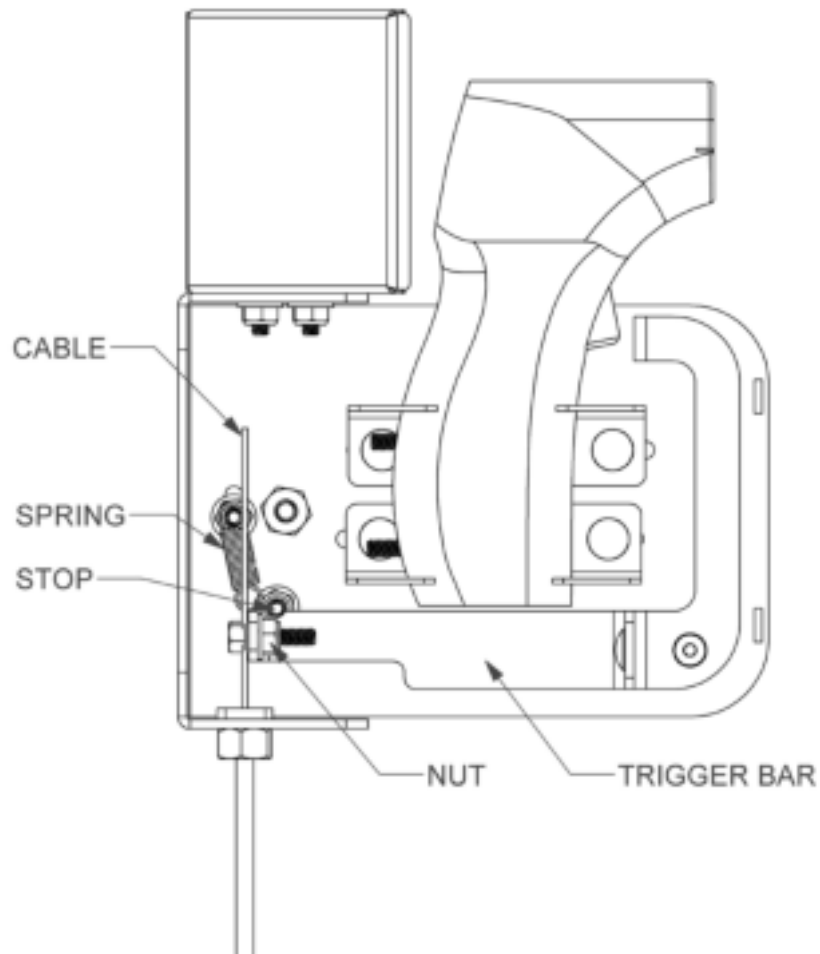





# 8. OPERATION

(Figure 5)

- 1) Align forehead 2 inches (50mm) from forehead thermometer
- ⚠ CAUTION** To avoid error, do not align with hair or perspiration
- 2) Press foot switch
  - 3) Read temperature output in mirror

Figure 5

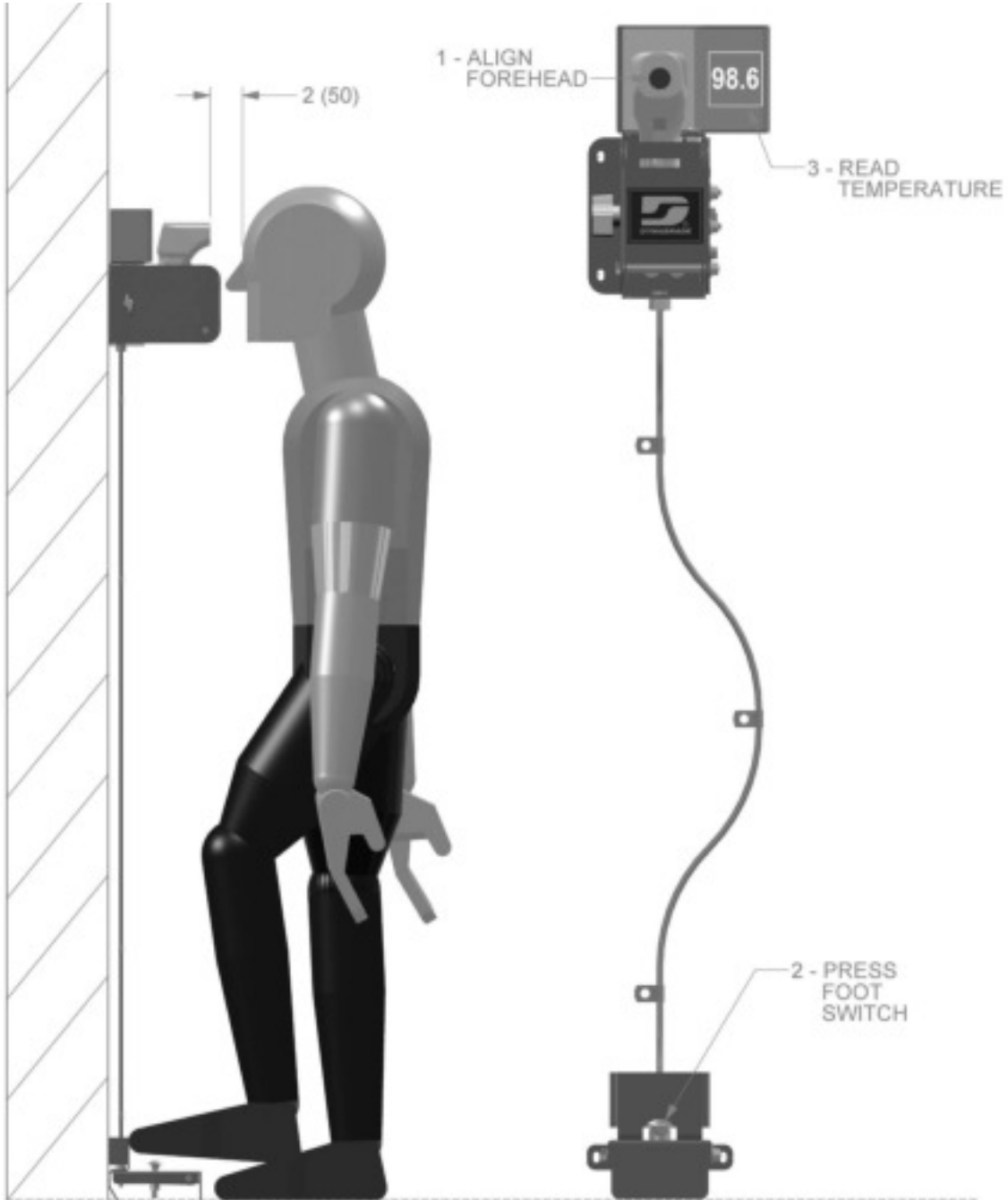



# 9. MAINTENANCE

- 1) Clean surfaces with a damp cloth
- 2) Do not use abrasive cleaners
- 3) Clean mirrors with glass cleaner

# 10. DIMENSIONS

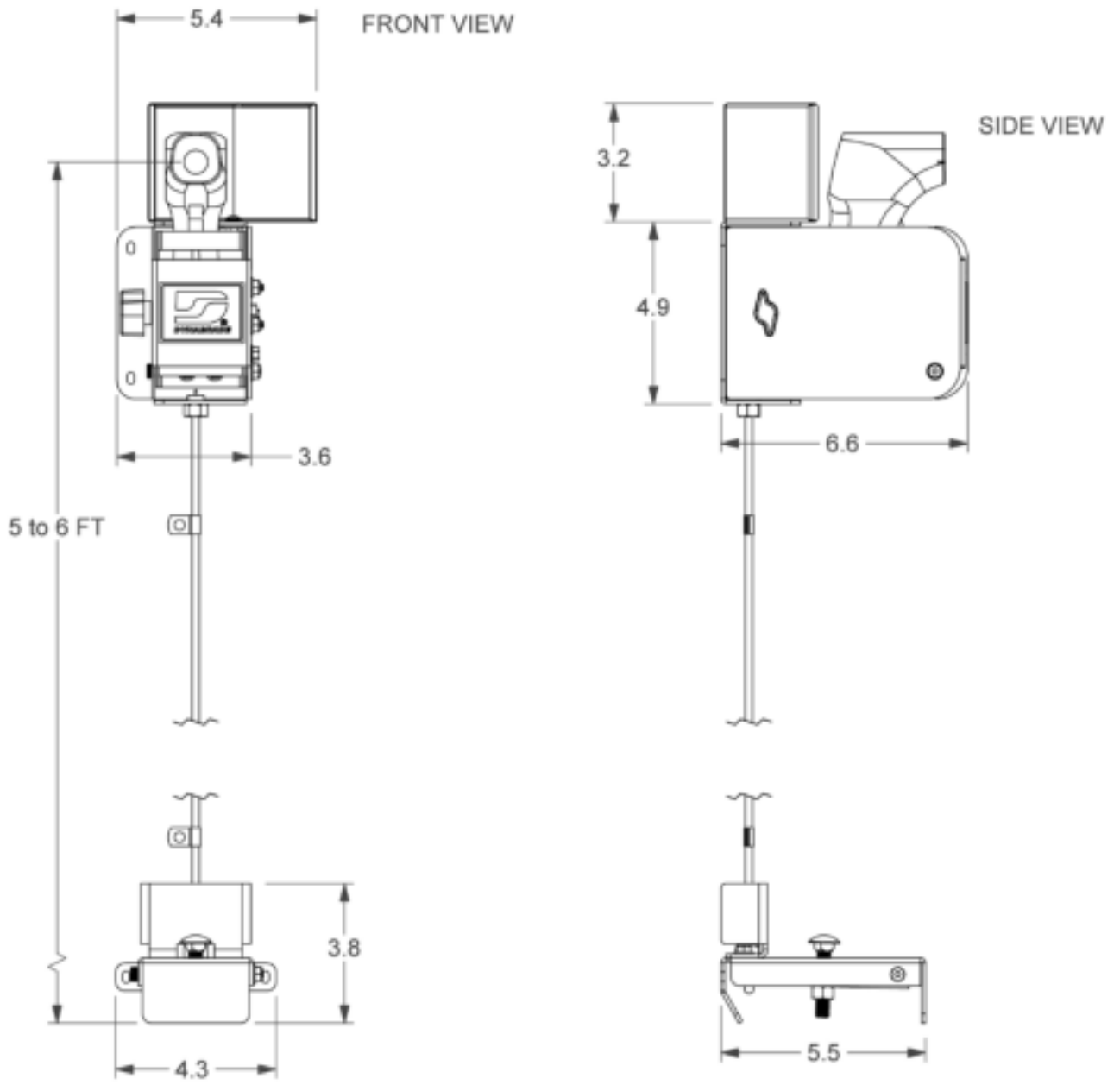



# 11. PARTS DIAGRAM

## 11.1 Lower Housing

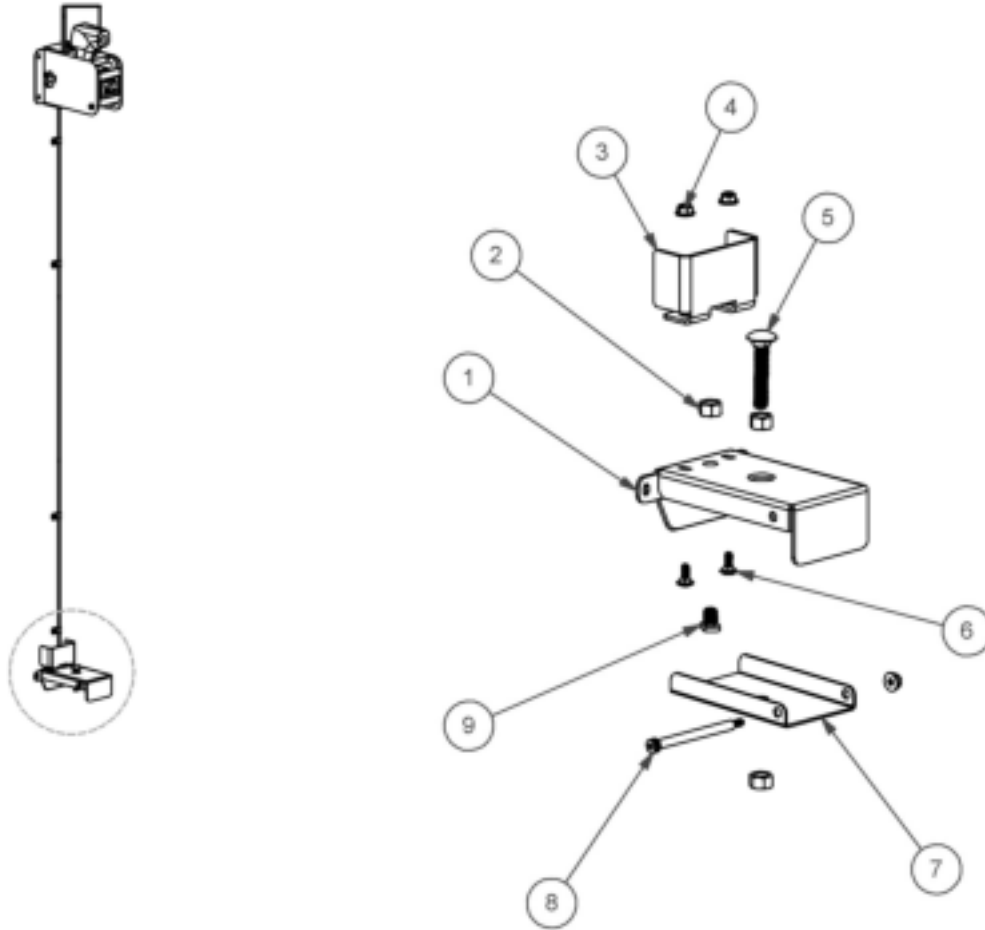

ITEM	PN	DESCRIPTION	QTY.
1	62131	FOOT SWITCH BASE	1
2	97217	3/8" HEX NUT	3
3	62133	TOE STOP	1
4	97451	10-24 FLANGE LOCK NUT	3
5	62168	CARRIAGE BOLT 2 X 3/8	1
6	62169	CARRIAGE BOLT 1/2 x 10-24	2
7	62132	FOOT SWITCH LEVER	1
8	62165	SHOULDER SCREW 3 x 1/4	1
9	62148	CABLE STOP	1



# 11. PARTS DIAGRAM

## 11.2 Upper Housing

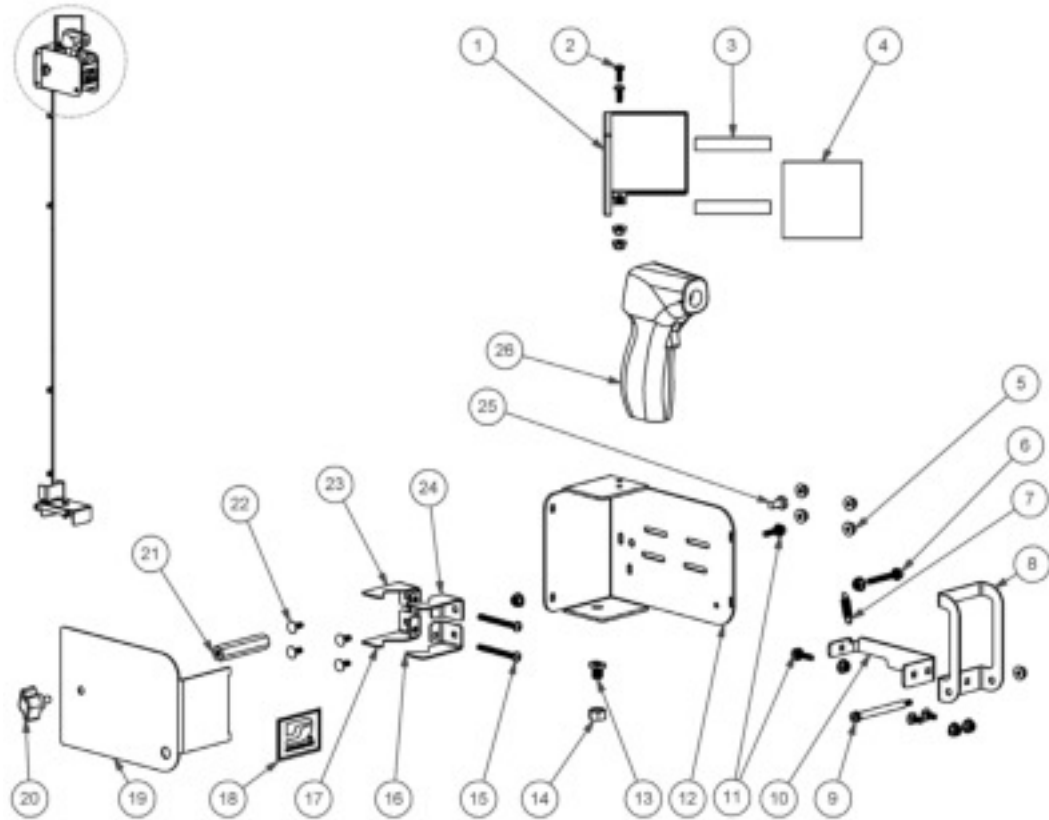

ITEM	P/N	DESCRIPTION	QTY.
1	62141	MIRROR BRACKET	1
2	62153	PAN HEAD SCREW 1/2 x 10-24	2
3	62146	HIGH BOND TAPE	4
4	62145	MIRROR	2
5	97451	10-24 FLANGE LOCK NUT	12
6	62160	HEX HEAD FLANGE SCREW 1-1/2 x 10-24	1
7	62151	EXTENSION SPRING 1-1/4 X 5/16	1
8	62140	TRIGGER	1
9	62154	SHOULDER SCREW 2-1/2 x 1/4	1
10	62139	TRIGGER BAR	1
11	62157	HEX HEAD FLANGE SCREW 3/4 x 10-24	2
12	62143	HOLDER BASE	1
13	62148	CABLE STOP	1
14	97217	3/8" HEX NUT	1
15	62152	PAN HEAD SCREW 2 x 10-24	2
16	62137	LOWER FRONT CLIP	1
17	62136	LOWER REAR CLIP	1
18	64929	DESCRIPTION PLATE, COMPANY LOGO	1
19	62142	COVER	1
20	64951	KNOB	1
21	62156	STANDOFF 2-1/2 x 1/4-20	1
22	62159	CARRIAGE BOLT 1/2 x 10-24	6
23	62135	UPPER REAR CLIP	1
24	62138	UPPER FRONT CLIP	1
25	95206	1/4-20 x 1/2" HEX HEAD BOLT, ZINC	1
26	62147	FOREHEAD THERMOMETER	1



# 11. PARTS DIAGRAM

## 11.3 Cable

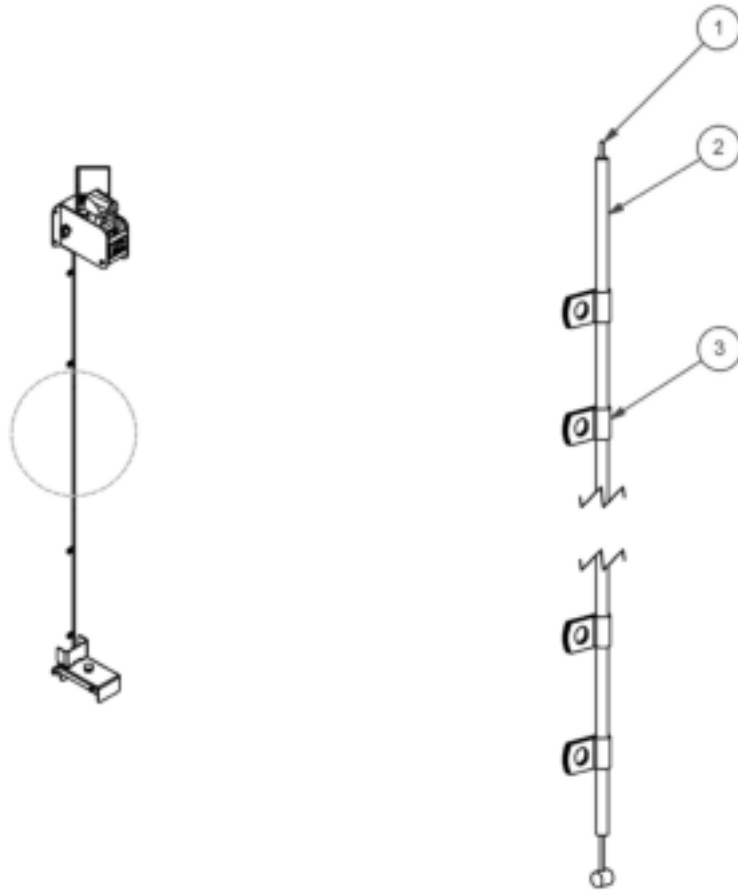

ITEM	P/N	DESCRIPTION	QTY.
1	62144	CABLE	1
2	62149	CABLE OUTER CASING	1
3	62150	LOOP CLAMP 3/16 x 1/2	4



# 12. WARRANTY

## Dynabrade Foot Activated Screening Thermometer 12 Month Warranty

Dynabrade warrants all Foot Activated Screening Thermometers against defects in workmanship and materials under normal use and service for a period of 12 months from the date of purchase as set forth herein. Customer must return the defective Foot Activated Screening Thermometer to Dynabrade within 12 months from the date of purchase. Upon examination and review at Dynabrade's factory, Dynabrade shall confirm whether the Foot Activated Screening Thermometer qualifies for warranty status, in which case Dynabrade shall repair or replace the Foot Activated Screening Thermometer at no charge to the customer. Exceptions for in-field examination shall be made only at Dynabrade's discretion.

This warranty is contingent upon proper assembly, installation, and use of the Foot Activated Screening Thermometer in accordance with factory recommendations, instructions and safety practices. It shall not apply to Foot Activated Screening Thermometers that have been subjected to misuse, negligence, accident or tampering in any way so as to affect its normal performance. This warranty does NOT cover the forehead thermometer, or its batteries. This warranty does NOT cover normally wearable parts and accessories, including, but not limited to, cables, and cable casings. This warranty does NOT cover chipped or damaged coatings or corrosion. To be considered for warranty, Foot Activated Screening Thermometers must be sent back to our factory, transportation prepaid by user. Please send Foot Activated Screening Thermometers back to attention "Repair Department" with a written explanation of the problem along with a copy of the original invoice indicating model and serial number if applicable.

**THIS WARRANTY IS MADE IN LIEU OF ALL OTHER WARRANTIES, EXPRESS OR IMPLIED, INCLUDING, BUT NOT LIMITED TO, WARRANTIES OF MERCHANTABILITY OR FITNESS FOR A PARTICULAR PURPOSE, AND THERE ARE NO OTHER WARRANTIES THAT EXTEND BEYOND THIS EXPRESS WARRANTY.**

Dynabrade will not be liable for damages to products, other property or persons due to improper use or through attempts to use products for other than their intended use.

**DYNABRADE WILL NOT BE LIABLE TO CUSTOMER OR ANY THIRD PARTY FOR ANY SPECIAL, CONTINGENT, INCIDENTAL, INDIRECT OR CONSEQUENTIAL DAMAGES.**

Dynabrade's liability with respect to a claim for any other damages arising out of or connected with the manufacture, sale, purchase, non-delivery, use or performance of any product sold by Dynabrade will in no event exceed to the price paid for the product.